



**Product Brochure
& Installation Manual**

ceramITeX[®]

Sintered Ceramic Facade System



ceramITeX[®]

Ceramitex[®] Sintered Ceramic Facade System simply outperforms. Our North American code compliant, large format, ultra strong panels are lightweight yet durable enough to defy graffiti, scratches, weather, and the test of time. The system is fabricated to your exacting specifications on our proprietary Unity[®] integrated attachment technology, giving you a complete solution engineered to beautify and protect your project.

Ceramitex[®] is offered in a wide array of colors and finishes for your facade. Take advantage of this revolutionary system that offers lasting allure and value for less than you might expect.

To learn more about **UNITY[®]**, our proprietary attachment technology, see page 9.



Index

- Features & Benefits 4-5
- Rear Ventilated Rainscreen (RVR) 6
- Product Specifications 7
- Shop Drawing Details 8
- Unity® Proprietary Attachment Technology 9
- Corner Details 10-11
- Packaging + Site Storage 12
- Handling 12
- System Components 13-14
- Sub-Framing 15
- Panel Installation 16-17
- Infill Strips 18
- Corners + Edges 19
- Details 20-22



Features & Benefits



Code Compliant

The Ceramitex® System is an architectural ceramic product proven to meet or exceed industry code standards throughout North America.



Climate Defiant

Resistant to expansion and contraction in high temperature or freezing conditions.



Lightweight

Sintered ceramic panels with a thickness of 6mm are approximately 3.8lbs per square foot.



Large Format

Large format sintered ceramic panels open a world of design possibilities. Offered in a range of colors and textures.



Impact Resistant

Ceramitex® panels are strong, lightweight and extremely resilient against high traffic abrasion.



Mitered Corners

Unique to the Ceramitex® System is the ability to create large mitered returns, giving a striking dimensional appearance to any returning edge.



Waterproof

Waterproof panels combined with a patented pressure-equalized rainscreen system provide the ultimate weather barrier.



Graffiti-Proof

Ceramitex® sintered ceramic panels are easy to maintain and impervious to chemicals.



UV Resistant

Since the color is 100% natural, it does not deteriorate due to exposure to the sun or extreme temperatures.



Scratch Resistant

Panels are resistant to scratching and abrasion due to the hardness of the surface.



Rear Ventilated Rainscreen

Rear Ventilated Rainscreen (RVR)

Our Rear Ventilated Rainscreen (RVR) System breathes freely and allows panels to repel water and debris.

Pressure-Equalized Rainscreen

Pressure-equalization reduces the pressure difference across the cladding through the use of compartmentalization and back venting. Ingress of incidental water is reduced and residual moisture is returned to the exterior at the drainage plane.

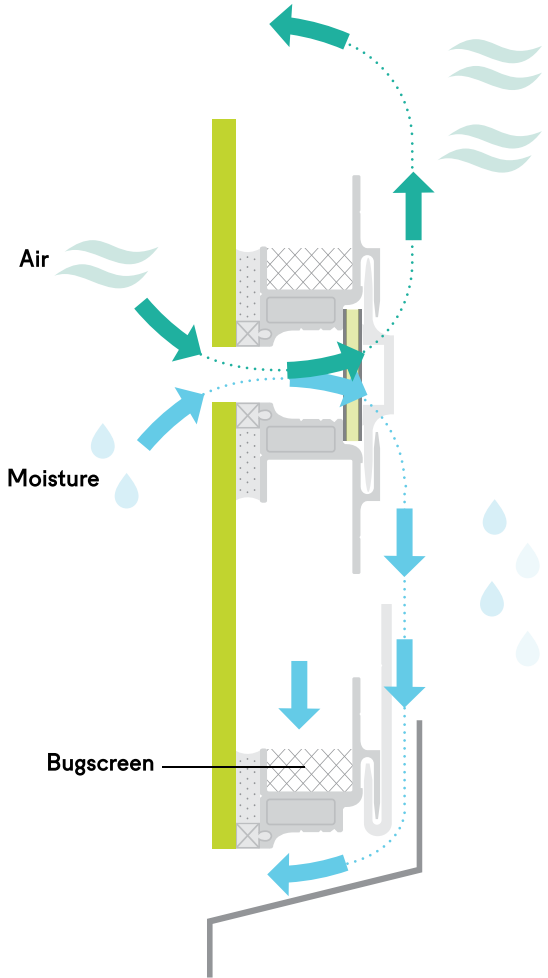



Product Specifications

Composition + Material

Ceramitex® sintered ceramic panels consist of a sintered ceramic slab manufactured with fiberglass reinforced mesh backing that is adhered to our proprietary Unity® attachment technology.

Sizing + Details

Panels are available in 5' x 10' (1524mm x 3048mm), 4' x 12' (1219mm x 3657mm), and 4' x 8' (1219mm x 2438mm) in the 6mm thickness and 4.5' x 10.5' (1440mm x 3200mm) in the 8mm. Standard panel thicknesses are 1/4" (6mm) and 5/16" (8mm). Additional thickness available is 1/2" (12mm).

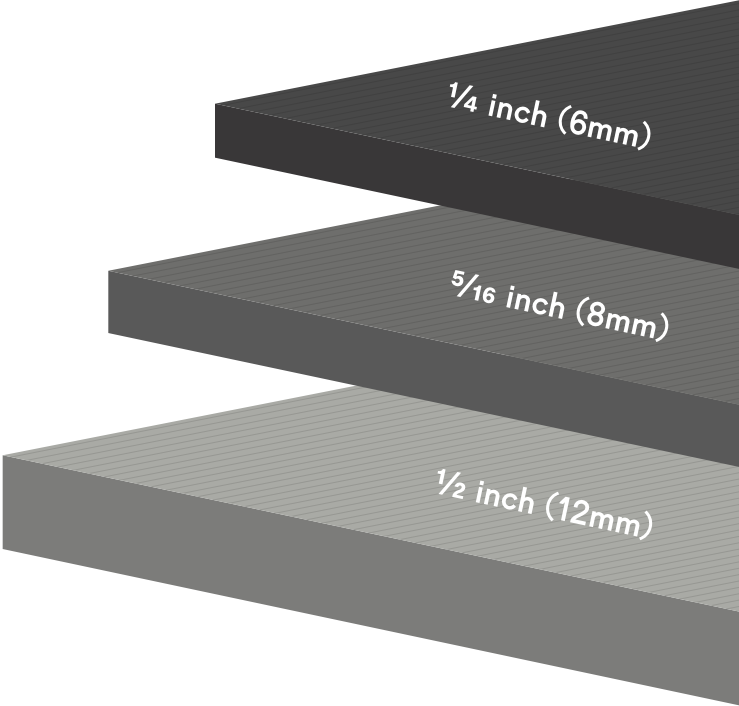
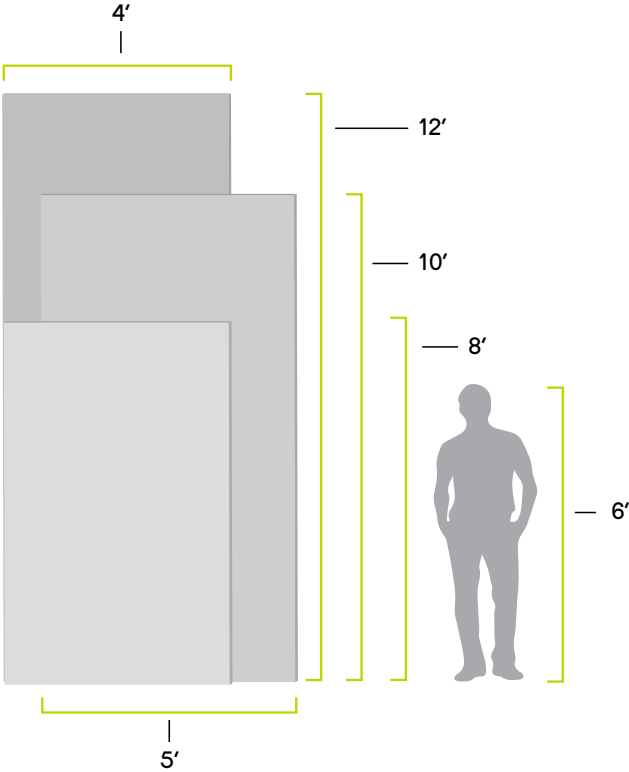

Shop Drawing Details

Shop Drawing Details

Ceramitex® panels are cut from shop drawings that are created by a team of experienced, qualified designers who work with the architect and installation contractor to meet the design intent. Once all Ceramitex® panel areas have been field measured and finalized with the installation crew, a set of fabrication tickets are created. The panels are then fabricated to the exact size in our highly automated, climate controlled production facility.

S2 Sample Shop Drawing

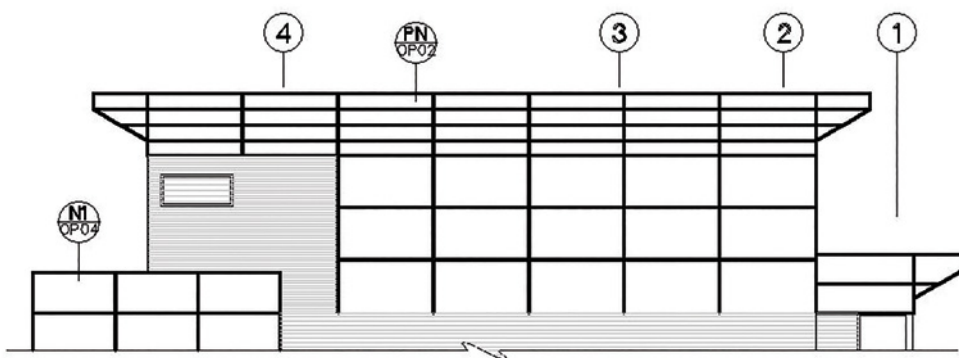

i All drawings must be reviewed by a local engineer following each region's building regulations and codes prior to fabrication.



Unity® Proprietary Attachment Technology

UNITY®

Unity® is our proprietary concealed attachment technology that supports simple and elaborate designs from flat panels to complex shapes. It seamlessly integrates with all of Elemex's facade surfaces using one proven system that offers multi-panel surface integration and the ability to design and install with absolute confidence. Unity® brings it all together for a new North American standard.

Panel Structure

The proprietary extruded aluminum framing consists of a perimeter frame and intermediate stiffeners.

Attaching

Sintered Ceramic is mounted to the frame and adhered with structural silicone.

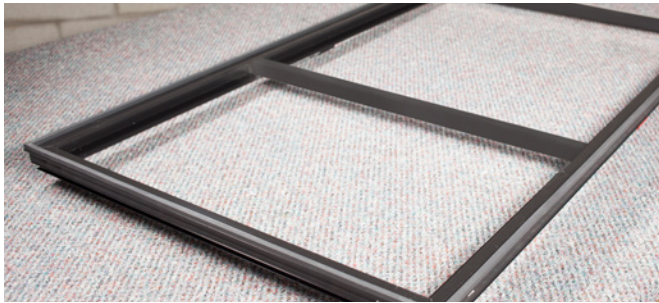



Inside Corners

Butt corner pieces are best to be constructed with sintered ceramic slabs 1/4" (6mm) or thicker.

Inside Corner

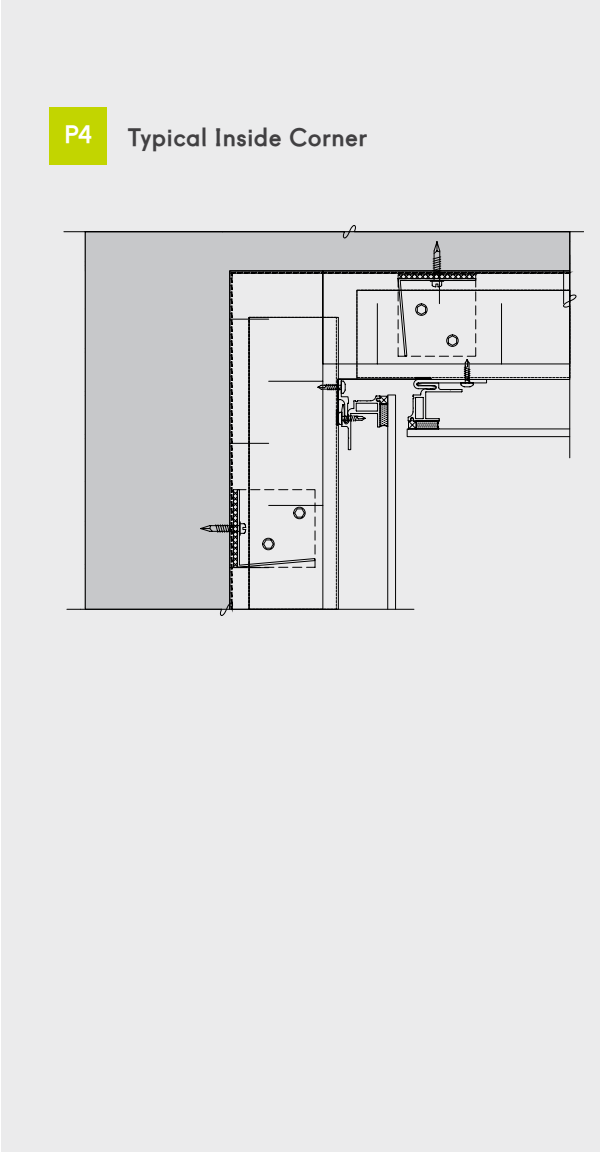
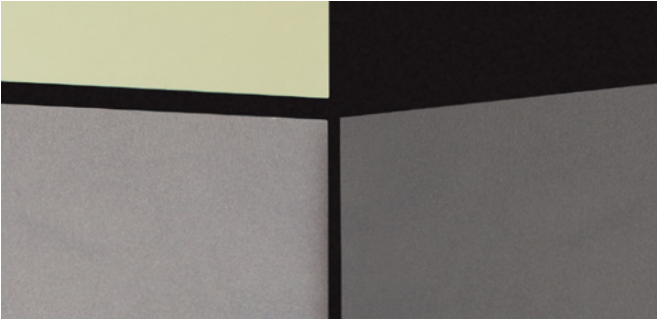



Outside Corners

Mitered corner panels are custom cut and appear seamless. These corner pieces are required to be constructed with Sintered Ceramic slabs $\frac{1}{4}$ " (6mm) or thicker.

Outside Mitered Corner

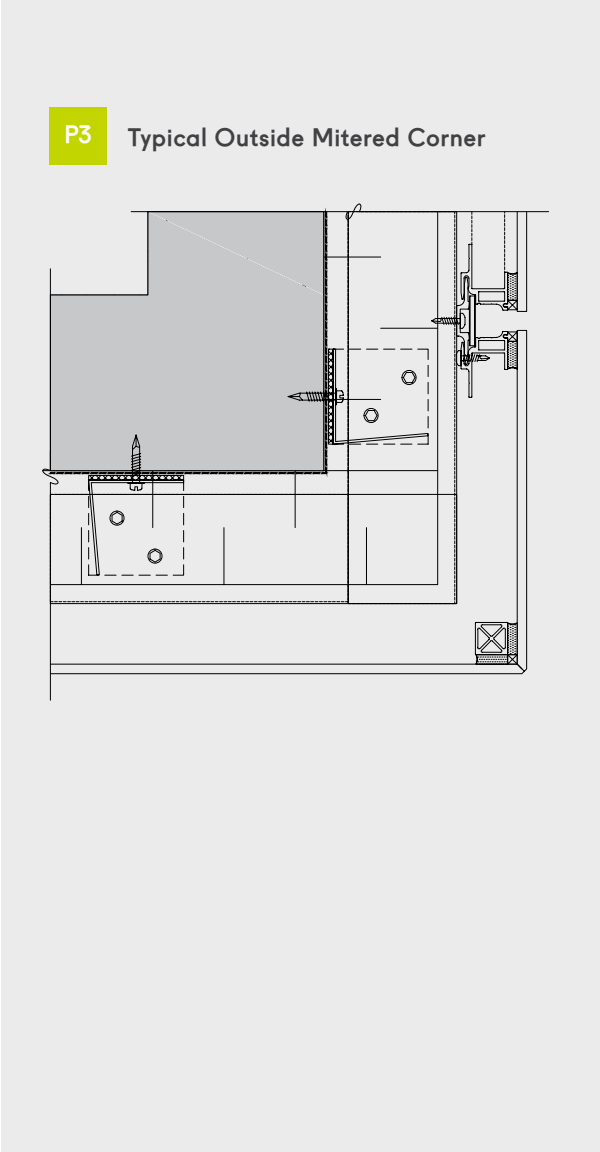



Packaging + Site Storage



The edges of the panels are protected by plastic clips during shipping and storage.



Skids and crates are custom built to ship panels to every project. Panels are numbered, packed and shipped in sequence based on the predetermined plan for installation.

Handling

A packing list is shipped with each crate so if any damage is sustained in the shipping process a replacement panel can be cut and expedited to the site. Panels are shipped in stages, based on a predetermined installation plan.

i Open edges of the panels could be vulnerable in some installations. Care must be taken during installation to ensure the panel edges are protected from chipping.

Store & Handling Recommendations

- 1** A forklift or crane should be used when moving crates.
- 2** Open crates from designated wall. "Open here" is labeled on the correct wall. Walls not designated with this label should not be removed.
- 3** Panels should be lifted off and removed from crates carefully, never slide them out as damage to panel may occur.
- 4** Always store panels upright and against stable structures. Panels should not be stored on top of each other flat.
- 5** Never sit/stand or place things on finished panels.

System Components

Supplies Checklist



Clamps



Screws



Drill



Level



Pry Bar



Spacers



Requires
2 Workers

The installation process includes a drill, screws, a level, spacers and a set of clamps to hold the panels in place. Aluminum clips are included to assist in the installation process.

There are two types of system applications:

Insulated Rainscreen

An insulated system starts with a predetermined air/vapor barrier that is affixed to a uniform substrate. Heavy (16-20 gauge) galvanized steel sub-framing attaches the Ceramitex® panel to the wall. The sub-framing provides a cavity for the insulation as well as providing a 1" (25mm) airspace.

Non-Insulated Rainscreen

A non-insulated system requires only an air barrier, and the panels may be mounted directly to the substrate.

i A minimum of 10mm of air space is recommended in order to promote proper ventilation in the Ceramitex® System.

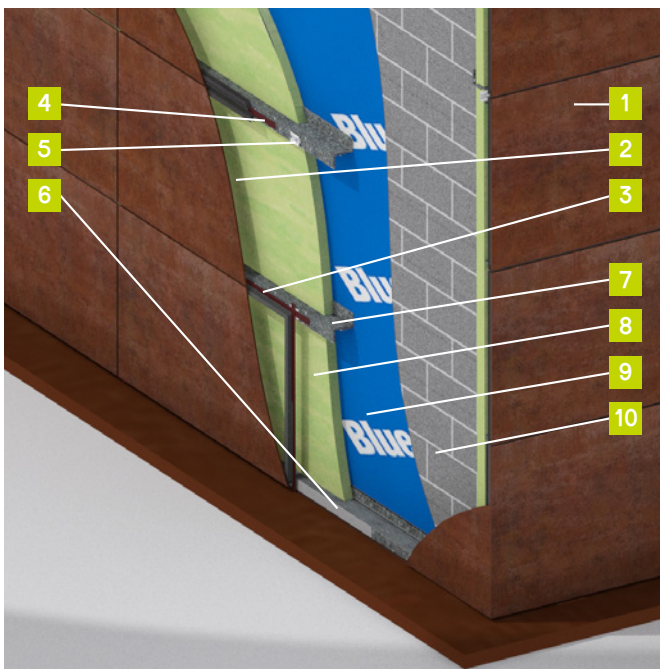

Diagram 1

Typical Outside Corner

Concrete Masonry Unit (CMU) Construction

- 1** Ceramitex® Sintered Ceramic Panel
- 2** 1" Air Space
- 3** Anodized Aluminum Cladding System Frame
- 4** Infill Strip
- 5** Aluminum Clip
- 6** Aluminum J-trim
- 7** Adjustable Galvanized "L" Angles or Z-girt (Thermally Broken EnviroClip®)
- 8** 3" Semi Rigid Insulation
- 9** Air/Vapor Barrier
- 10** Concrete Masonry Unit (CMU)

i Check your local building code for local structural, insulation and air/vapor barrier requirements.

Diagram 2

Typical Inside Corner

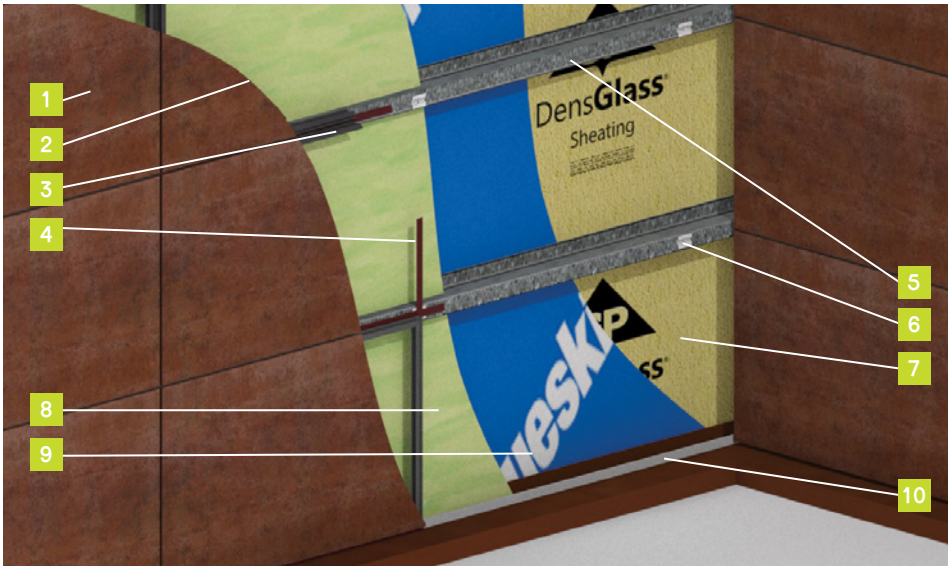

- 1 Ceramitex® Sintered Ceramic Panel
- 2 1" Air Space
- 3 Anodized Aluminum Cladding System Frame
- 4 Infill Strip
- 5 Adjustable Galvanized "L" Angles or Z-girt (Thermally Broken)
- 6 Aluminum Clip
- 7 Metal Structural Framing with Sheathing
- 8 3" Semi Rigid Insulation
- 9 Air/Vapor Barrier
- 10 Aluminum J-Trim

Substrate: Metal Structural Framing With Sheathing

Diagram 3

Typical Window Jamb

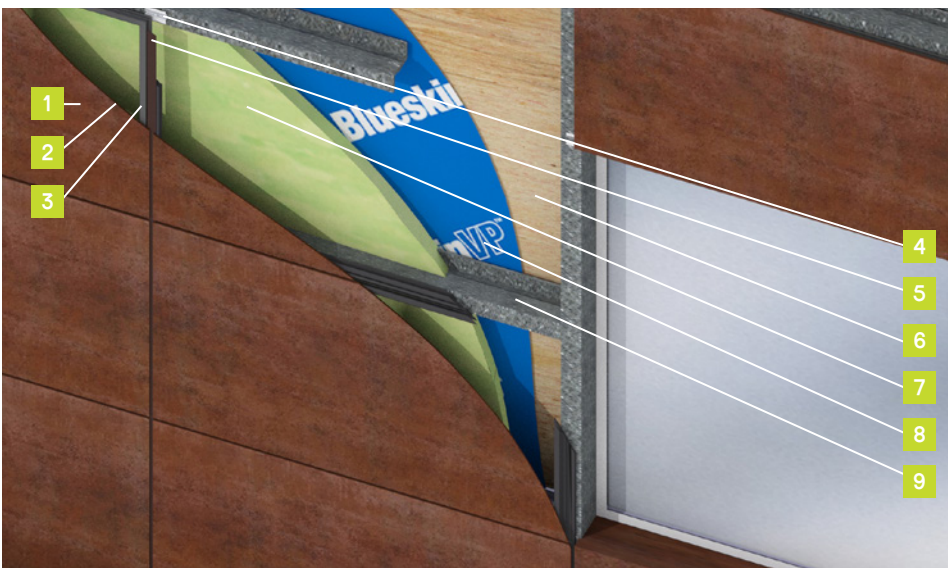

- 1 Ceramitex® Sintered Ceramic Panel
- 2 1" Air Space
- 3 Anodized Aluminum Cladding System Frame
- 4 Aluminum Clip
- 5 Infill Strip
- 6 Wood or Structural Steel Framing with Plywood
- 7 3" Semi Rigid Insulation
- 8 Air/Vapor Barrier
- 9 Adjustable Galvanized "L" Angles or Z-girt (Thermally Broken)

Substrate: Wood or Structural Steel Framing With Plywood

Sub-Framing

The Ceramitex® Sintered Ceramic Facade System can be mounted on a vertical or horizontal adjustable thermally broken galvanized framing system. Framing can be installed vertically or horizontally on concrete block or poured concrete but in most cases vertical framing is used. If the substrate is constructed with vertical steel studs, horizontal framing is preferred. The project design will dictate how the sub-framing will be installed.

Ceramitex® sintered ceramic panels are attached using aluminum clips at a maximum of 24" (600mm) on center to the sub-framing.

i Technical data on panel size and including additional girts to the layout are available.

All drawings must be reviewed by a local engineer following each region's building regulations and codes prior to fabrication.

Typical Vertical Framing



Typical Horizontal Framing

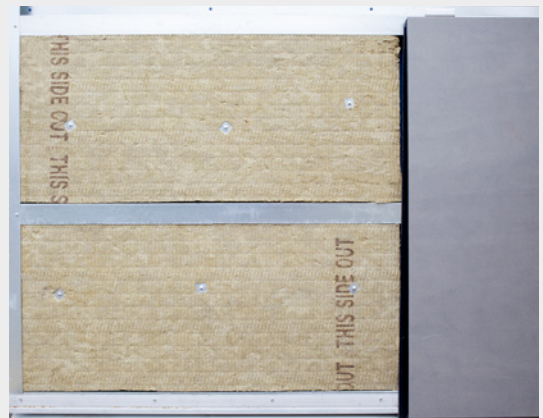



Panel Installation



1 J-trim is mounted to the sub-framing at the base of the wall over top of the flashing.



2 Before installing the panels, the installer must ensure that the J-trim is clear of all debris.



3 The panel is placed face down on a table and the aluminum clips are installed to align with the sub-framing system.



4 The panel is placed into the J-trim.



5 The installer ensures that the panel is level.



6 The aluminum clip is attached to the sub-framing using a self-drilling hex screw with an extended hex head driver.



7 Repeat steps 3-5. The next panel is placed onto the J-trim and slid over to connect with the previous panel installed.

i In the example shown, the side clip does not connect directly with the framing, but provides panel support, spacing and a guide for the infill strip.



8 Minor adjustments can be made to the panel spacing. Spacers can be used to ensure consistent spacing between panels before they are attached to the framing system.



Infill Strips



9 **Vertical** infill strips are measured and installed once a row of panels are installed.



10 **Horizontal** infill strips are then installed across the top of the row of panels.



Infill strips can match or complement the system frame color as part of the Ceramitex® Concealed Installation System. The infill strips conceal any visible clips or screws.

i Infill strips are also available in custom colors.

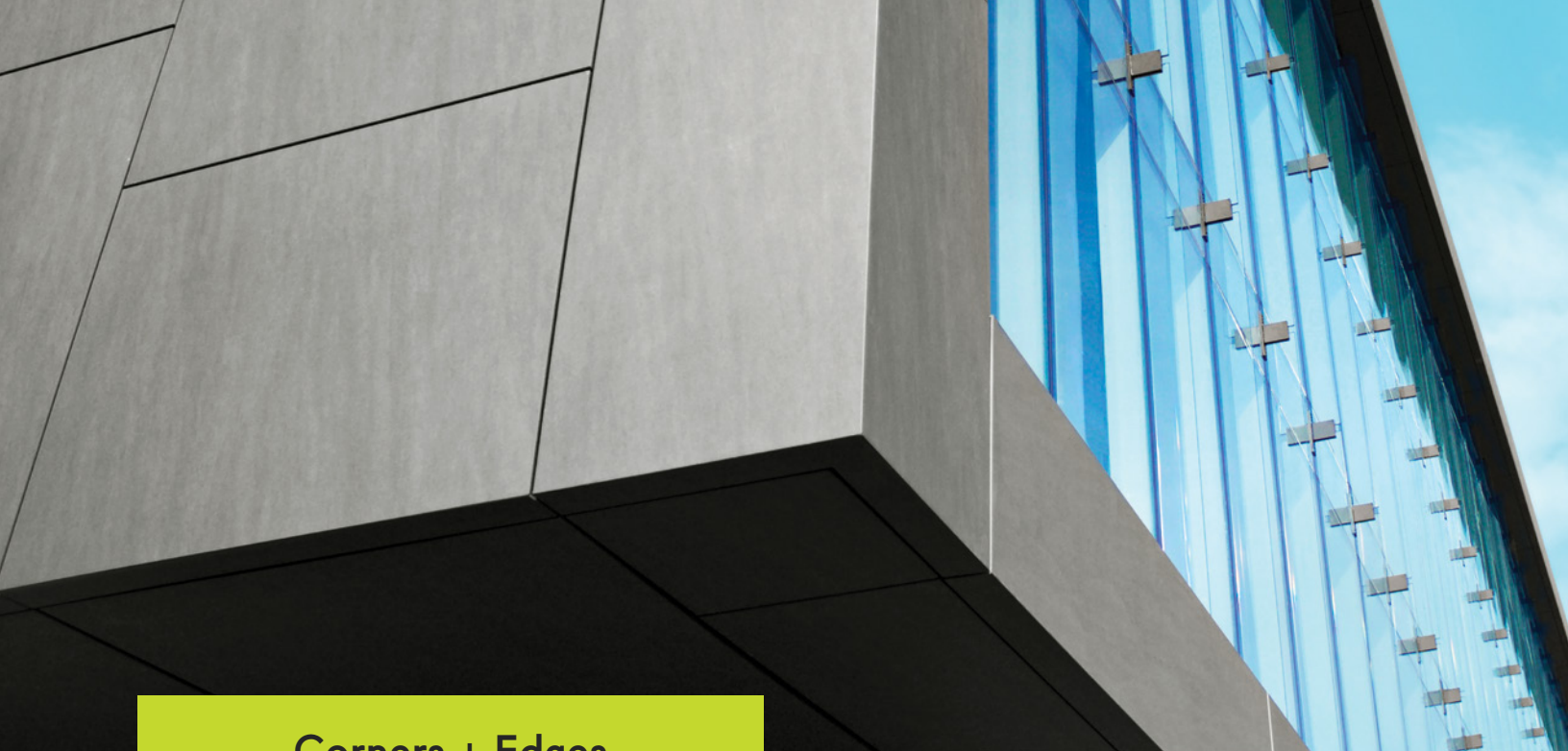

Corners + Edges

It's recommended that installation begins at a corner or window jamb. Corner and window jamb panels will determine the plane of the wall.



Mitered corners or jambs are installed in the same manner flat panels are installed.



Routed infill strips will be required at inside corners and may be required behind windows and door jambs. Alternatively, flashings can be used at window and door jambs.



Infill strips can be routed from the back and bent to create a clean corner.

Details

S1A Specialty Parapet Cap

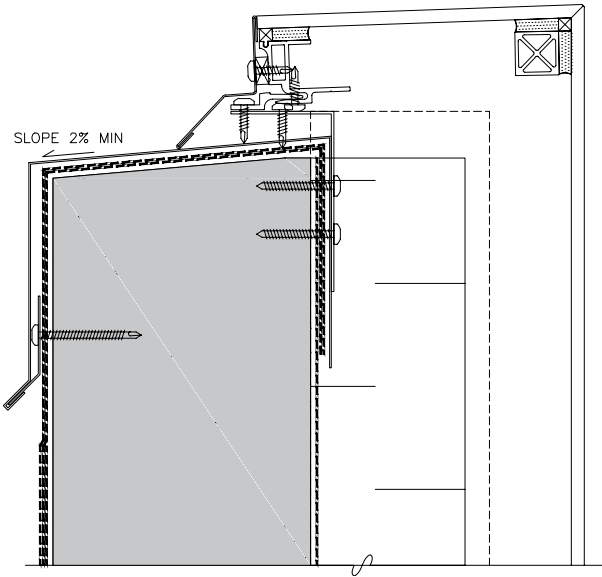

S1B Typical Parapet Cap

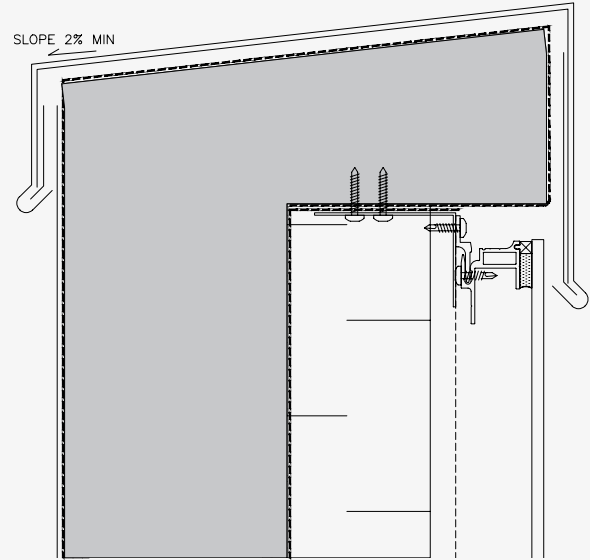

S4 Typical Curtain Wall Head

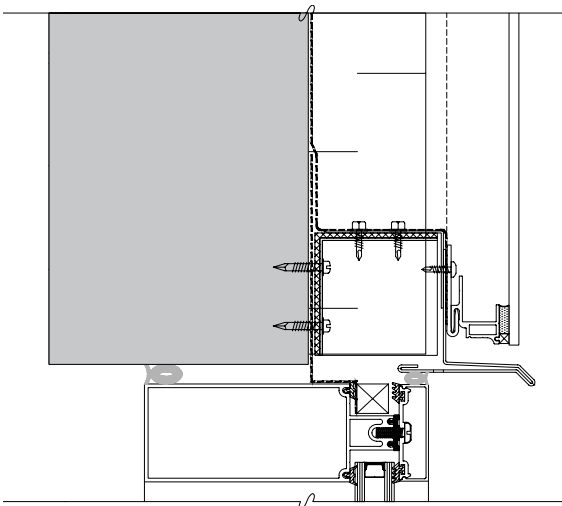

S5 Typical Curtain Wall Sill

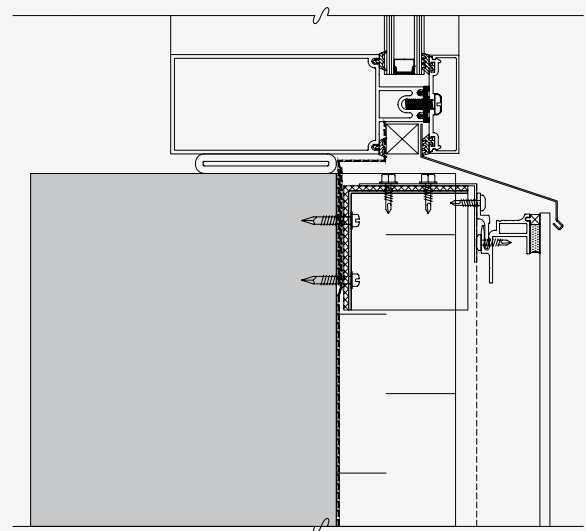

S6 Typical Horizontal Joint

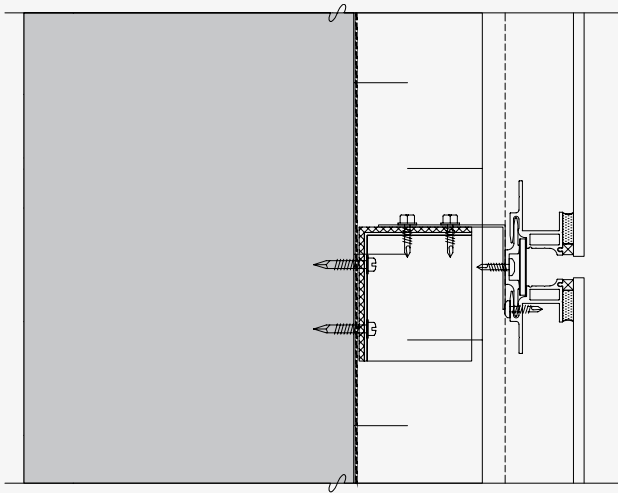

S7 Typical Base of Wall

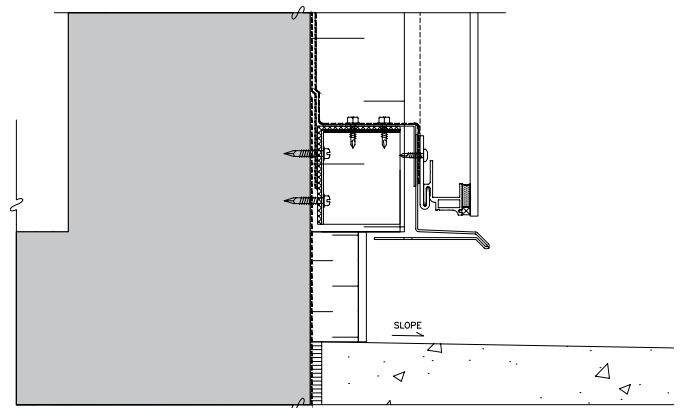

P1B Metal Closure Return Window Jamb

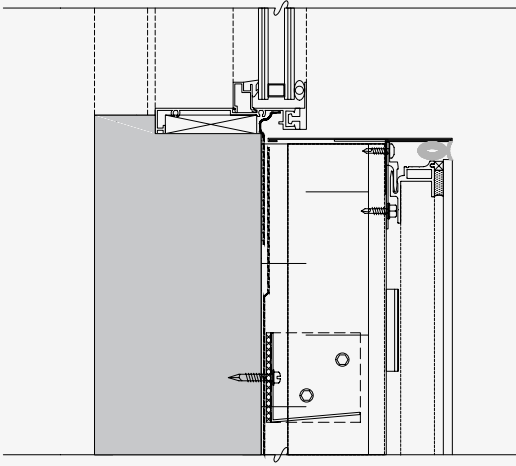

P1A Ceramic Return Window Jamb

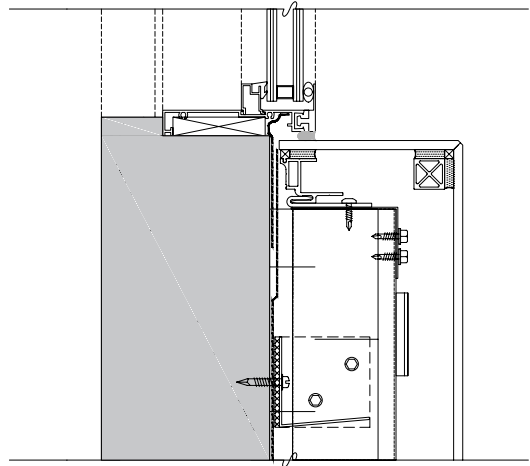

P3 Typical Outside Corner

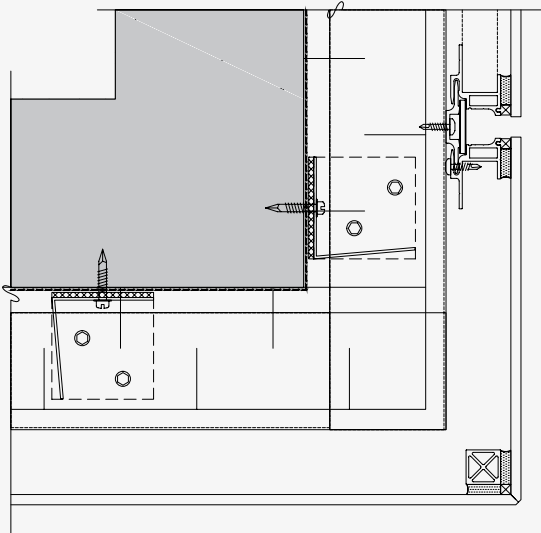

P4 Typical Inside Corner

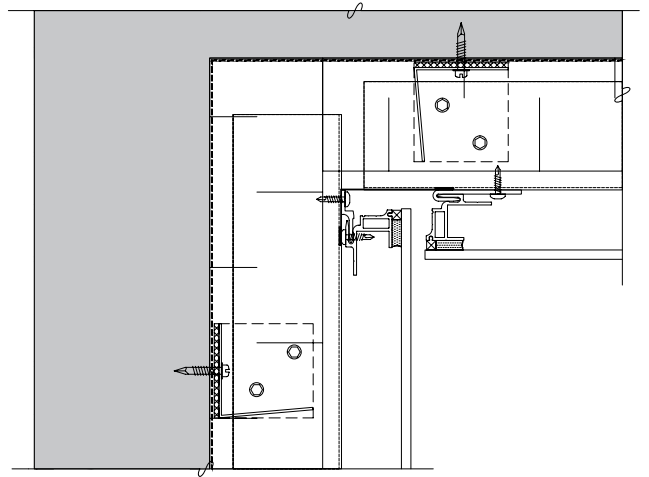



ceramITeX[®]

ceramitex.com



Architectural Facade Systems